

Clarke®



SUBMERSIBLE TRANSFER PUMP

MODEL NO: STP12

PART NO: 7260050

OPERATION & MAINTENANCE INSTRUCTIONS

UK
CA | CE



ORIGINAL INSTRUCTIONS

DL0223 - ISS 4

INTRODUCTION

Thank you for purchasing this CLARKE product.

Before attempting to use this product, please read this manual thoroughly and follow the instructions carefully. In doing so you will ensure the safety of yourself and that of others around you, and you can look forward to your purchase giving you long and satisfactory service.

LIMITATIONS OF USE

This pump must only be used to transfer:

- Clean water
- Diesel fuel
- Paraffin

DO NOT use this pump for pumping:

- Slurry
- Septic tanks
- Sandy or dirty water



WARNING: DO NOT USE FOR PUMPING PETROL

GUARANTEE

This product is guaranteed against faulty manufacture for a period of 12 months from the date of purchase. Please keep your receipt which will be required as proof of purchase.

This guarantee is invalid if the product is found to have been abused or tampered with in any way, or not used for the purpose for which it was intended.

Faulty goods should be returned to their place of purchase, no product can be returned to us without prior permission.

This guarantee does not effect your statutory rights.

ENVIRONMENTAL RECYCLING POLICY



Through purchase of this product, the customer is taking on the obligation to deal with the WEEE in accordance with the WEEE regulations in relation to the treatment, recycling & recovery and environmentally sound disposal of the WEEE.

In effect, this means that this product must not be disposed of with general household waste. It must be disposed of according to the laws governing Waste Electrical and Electronic Equipment (WEEE) at a recognised disposal facility.

CONTENTS

12 Volt Submersible Pump (with 3.8 m supply cable with crocodile clips)	2 x hose clips
15mm metal delivery tube	3m delivery hose

Please check the contents to ensure they are complete and that no transit damage has occurred. Should any damage be apparent, please contact your Clarke dealer immediately.

SPECIFICATIONS

Flow Rate	21 litres/min. for diesel and kerosene 19 litres/min. for clean water
Minimum Water Depth	40 mm
Pump Outlet Size	19 mm (external diameter)
Voltage	12 V
Current	4.5A DC
Pressure	0.23 bar
Height	160 mm
Diameter	55.5 mm
Weight	0.67 kg
Duty Cycle	15 mins on, 15 mins off in 30 min cycle

SAFETY INSTRUCTIONS

1. ALWAYS disconnect the pump from the power supply before carrying out maintenance operations.
2. ALWAYS examine the power cable before use to make sure that it is not damaged.
3. ALWAYS make sure that the filter is clean and serviceable before use.
4. Do not let the pump run dry (Minimum water depth is 40 mm).
5. DO NOT exceed the duty cycle - see Specifications.
6. DO NOT use the pump if any parts appear to be damaged. Have the pump repaired by your Clarke dealer.
7. DO NOT use the pump for any purpose other than that for which it is intended.
8. DO NOT operate the pump continuously - e.g. in a fish pond or collection tank, water feature etc.
9. DO NOT use or keep the pump in freezing conditions.
10. DO NOT allow uncontrolled discharge of contaminated liquid etc. ALWAYS collect in a container and dispose of according to all H&S regulations and local laws.

USING THE PUMP

1. Always make sure that the pump is in a good working condition and:
 - has no signs of damage
 - the filter is in place and perfectly clean
 - the power cable is in perfect condition
2. Attach the flexible hose to the outlet, securing with the hose clip supplied.
3. If required, attach the metal tube to the discharge end of the flexible hose, securing with the hose clip supplied.
4. Carefully lower the pump into the tank or sump etc., to be drained.
5. Connect the clamps to the 12 Volt battery and use the in-line switch to turn the pump on.

IMPORTANT: Connect the red - positive clamp to the red positive terminal of the battery FIRST, then connect the black clamp to the black - negative terminal, ensuring both clamps are perfectly secure.

6. When disconnecting - ALWAYS disconnect the black - negative clamp FIRST.
7. Always observe the pump discharge. Should flow/performance deteriorate during use, it is probable that the filter is becoming blocked.

UNBLOCKING THE FILTER

1. Disconnect the pump from the battery - black terminal first, then carefully withdraw the pump from the pit or sump etc. DO NOT yank the cable.
2. Unscrew the base and remove the filter. Either clean thoroughly or replace as necessary, then check the impeller to ensure it is free to rotate and is not blocked.
3. When satisfied, replace pump in sump or pit etc., and proceed to pump once more.
4. When finished, ALWAYS remove the filter and clean it thoroughly, then allow it to dry.
5. Thoroughly clean the pump with clean water and ensure the impeller is completely free to rotate and is free of any contaminants.
6. Reassemble the pump and store in a clean, dry environment.

EXPLODED PART LIST AND DIAGRAM

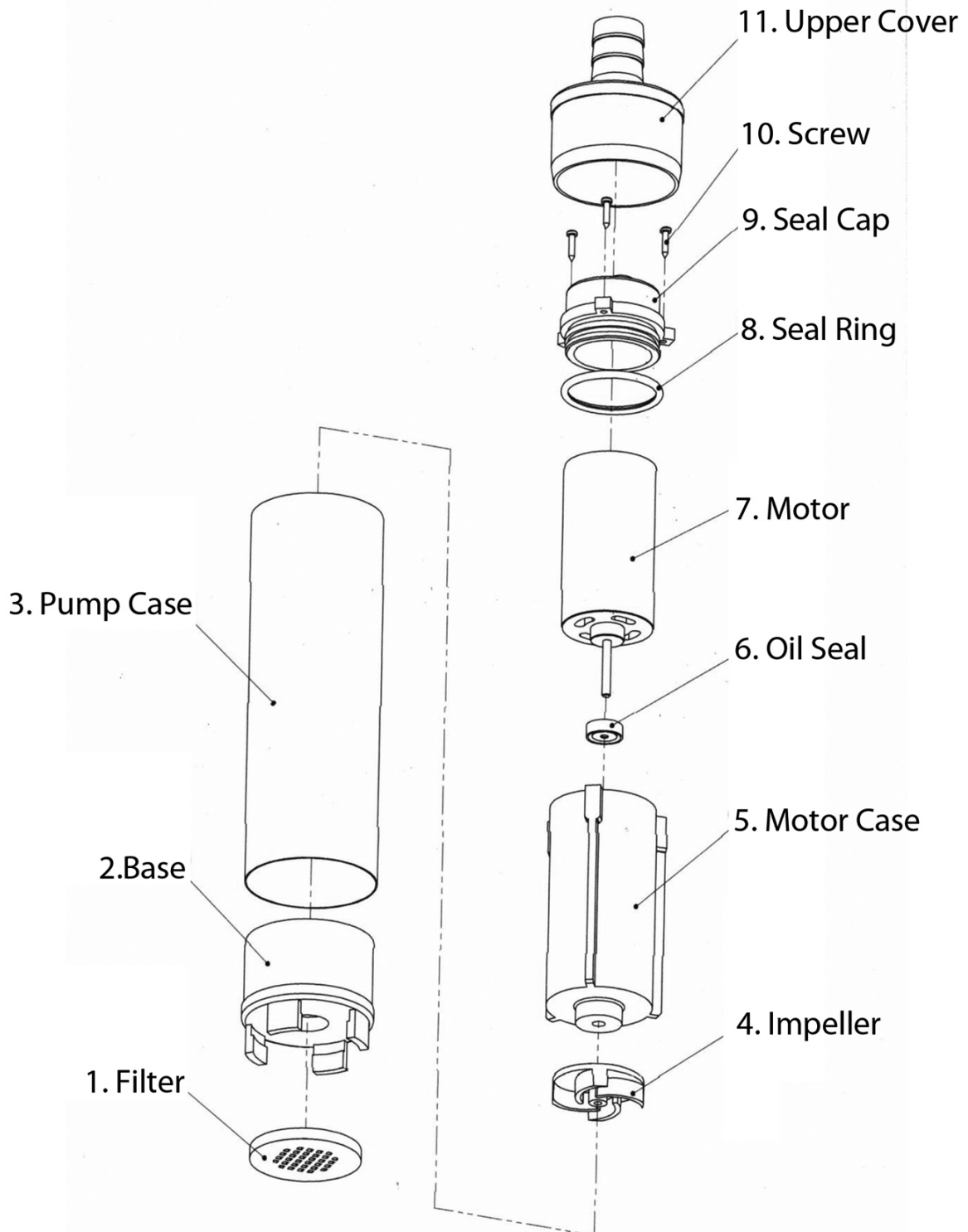

DECLARATION OF CONFORMITY

UK
CA

Clarke
INTERNATIONAL

Hemnal Street, Epping, Essex, CM16 4LG

DECLARATION OF CONFORMITY

This is an important document and should be retained.

We hereby declare that this product(s) complies with the following legislation:

Electromagnetic Compatibility Regulations 2016
Supply of Machinery (Safety) Regulations 2008
The Restriction of the Use of Certain Hazardous Substances in Electrical and Electronic Equipment Regulations 2012

The following standards have been applied to the product(s):

EN ISO 12100:2010, EN 809:1998+A1:2009/AC:2010, EN IEC 61000-6-1:2019,
EN 61000-6-3:2007/A1:2011/A/C:2012, EN 62321-1:2013, EN 62321-2:2014, EN 62321-3-1:2014,
EN 62321-8:2017.

The technical documentation required to demonstrate that the product(s) meet(s) the requirement(s) of the aforementioned legislation has been compiled and is available for inspection by the relevant enforcement authorities.

The UKCA mark was first applied in: 2023

Product Description: 12V Submersible Transfer Pump

Model Number(s): STP-12

Serial/Batch Number: Refer to product/packaging label

Date of Issue: 15/02/2023

Signed:



J.A Clarke
Director

CE

Clarke
INTERNATIONAL

Fitzwilliam Hill, Fitzwilliam Place, Dublin 2

DECLARATION OF CONFORMITY

This is an important document and should be retained.

We hereby declare that this product(s) complies with the following legislation:

2014/30/EU Electromagnetic Compatibility Directive
2006/42/EC Machinery Directive
2011/65/EU Restriction of the Use of Certain Hazardous Substances in Electrical & Electronic Equipment (RoHS) Directive

The following standards have been applied to the product(s):

EN ISO 12100:2010, EN 809:1998+A1:2009/AC:2010, EN IEC 61000-6-1:2019,
EN 61000-6-3:2007/A1:2011/A/C:2012, EN 62321-1:2013, EN 62321-2:2014, EN 62321-3-1:2014,
EN 62321-8:2017.

The technical documentation required to demonstrate that the product(s) meet(s) the requirement(s) of the aforementioned legislation has been compiled and is available for inspection by the relevant enforcement authorities.

The CE mark was first applied in: 2014

Product Description: 12V Submersible Transfer Pump

Model Number(s): STP-12

Serial/Batch Number: Refer to product/packaging label

Date of Issue: 15/02/2023

Signed:

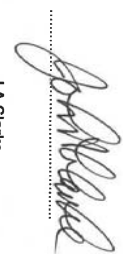

J.A Clarke
Director

A SELECTION FROM THE VAST RANGE OF

Clarke®

QUALITY PRODUCTS



AIR COMPRESSORS

From DIY to industrial, Plus air tools, spray guns and accessories.

GENERATORS

Prime duty or emergency standby for business, home and leisure.

POWER WASHERS

Hot and cold, electric and engine driven - we have what you need

WELDERS

Mig, Arc, Tig and Spot. From DIY to auto/industrial.

METALWORKING

Drills, grinders and saws for DIY and professional use.

WOODWORKING

Saws, sanders, lathes, mortisers and dust extraction.

HYDRAULICS

Cranes, body repair kits, transmission jacks for all types of workshop use.

WATER PUMPS

Submersible, electric and engine driven for DIY, agriculture and industry.

POWERTOOLS

Angle grinders, cordless drill sets, saws and sanders.

STARTERS/CHARGERS

All sizes for car and commercial use.

PARTS & SERVICE: 0208 988 7400

Parts Enquiries
Parts@clarkeinternational.com

Servicing & Technical Enquiries
Service@clarkeinternational.com

SALES: UK 01992 565333 or Export 00 44 (0)1992 565335

Clarke INTERNATIONAL Hemnall Street, Epping, Essex CM16 4LG
www.clarkeinternational.com